

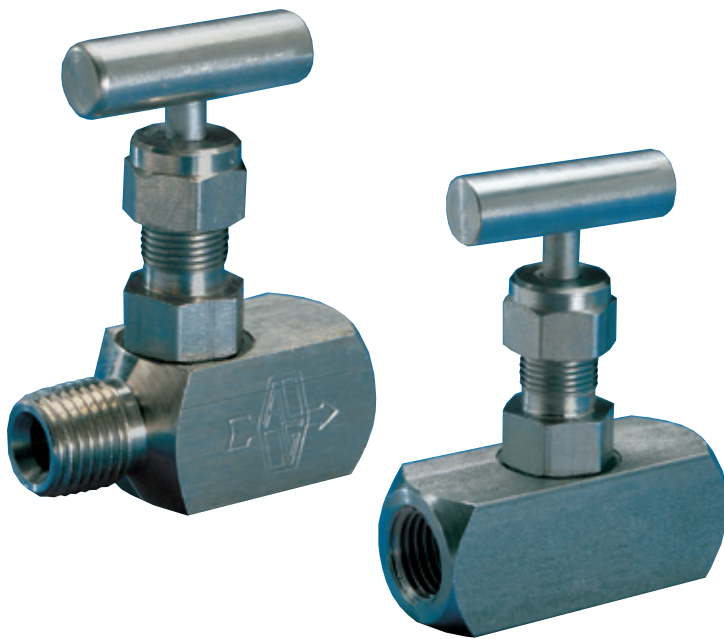

## ANDERSON GREENWOOD H5 MINIATURE HAND VALVE

A miniature isolation valve with an interchangeable hard or soft seat for pressures to 6000 psig (414 barg)



### FEATURES

- Packing below threads (O-ring bonnet) prevents lubricant washout, thread corrosion, process contamination and eliminates galling.
- Easily adjustable packing decreases replacement downtime and increases valve life.
- Safety back seating prevents stem blowout or removal during operation and provides a metal-to-metal secondary stem seal while in the fully open position.
- ENC plated 316 SS prevents galling or freezing of stem threads.
- Rolled stem, bonnet and male NPT threads provide additional strength.
- Mirror stem finish in the packing area enables smooth operation and extends packing life.
- One-piece handle design prevents loss due to vibration or during maintenance.
- Soft or metal seat for bubble-tight shutoff is field-replaceable for easy maintenance.
- Extended valve life: damaged soft seat can be removed, leaving a metal seated valve.

### GENERAL APPLICATION

The H5 mini valves facilitate safe, compact and economical installations and are excellent for straight isolation applications.

### TECHNICAL DATA

Materials:	CS, SS, Brass, Hastelloy
Seats:	Metal and soft
Connections	
Inlet:	¼" NPT
Outlet:	¼" NPT
Pressure (max.):	6000 psig (414 barg)
Temperature (max.):	1000°F (538°C)

# ANDERSON GREENWOOD H5 MINIATURE HAND VALVE

## SPECIFICATIONS

### H5 SPECIFICATIONS<sup>(3)</sup>

Dimensions, inches (mm)

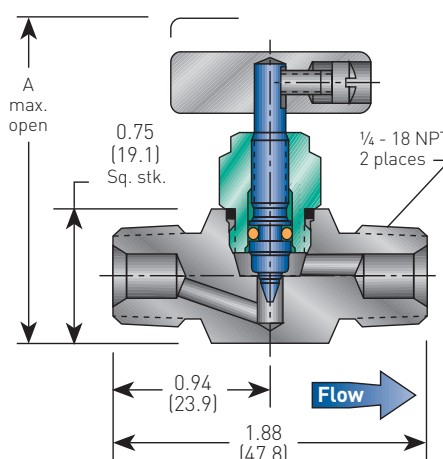
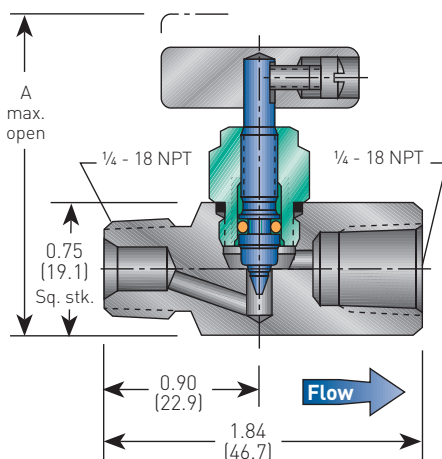
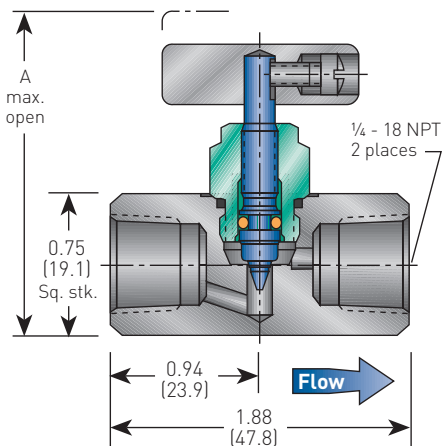

#### MAXIMUM OPEN - Dimension A

O-ring	PTFE	GRAFOIL®
2.00 (50.8)	2.60 (66.0)	3.07 (78.0)

#### MAXIMUM OPEN - Dimension A

O-ring	PTFE	GRAFOIL®
2.00 (50.8)	2.60 (66.0)	3.07 (78.0)

#### MAXIMUM OPEN - Dimension A

O-ring	PTFE	GRAFOIL®
2.00 (50.8)	2.60 (66.0)	3.07 (78.0)

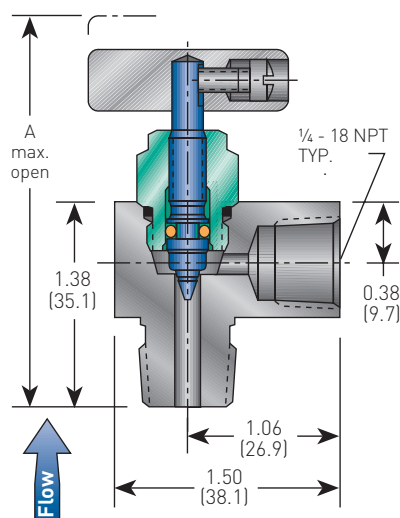
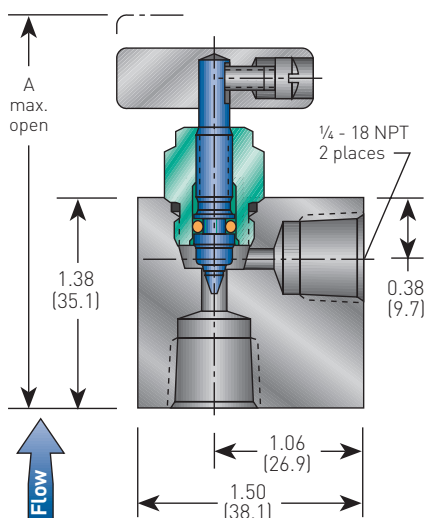

#### MAXIMUM OPEN - Dimension A

O-ring	PTFE	GRAFOIL®
2.64 (67.1)	3.23 (82.0)	3.71 (94.2)

#### MAXIMUM OPEN - Dimension A

O-ring	PTFE	GRAFOIL®
2.66 (67.6)	3.26 (82.8)	3.73 (94.7)

### NOTES

1. Approximate valve weight: 0.5 lb (.23 kg). Seat orifice size 0.136 inch (3.5 mm) diameter.
2. Valve C<sub>v</sub> soft seat 0.27 maximum.  
Valve C<sub>v</sub> hard seat 0.31 maximum.
3. For Hastelloy® and -SG3 call factory for dimensions and weights.

# ANDERSON GREENWOOD H5 MINIATURE HAND VALVE

## SPECIFICATIONS

### STANDARD MATERIALS - METAL HARD SEAT

Valve	Body	Bonnet	Stem	Packing	Seat	Handle <sup>[2]</sup>
CS <sup>[1]</sup>	A108	A108	A581-303	PTFE or FKM O-ring	Integral	Round
SS	A479-316	A479-316	A276-316	PTFE, FKM O-ring or Grafoil <sup>®</sup>	Integral	Tee
Brass	B16	B16	A581-303	PTFE or FKM O-ring	Integral	Round
SG <sup>[3]</sup>	A479-316	A479-316	Monel <sup>®</sup> R405	PTFE or FKM O-ring	Integral	Tee
SG3 <sup>[6]</sup>	Hastelloy <sup>®</sup> C-276	Hastelloy <sup>®</sup> C-276	Hastelloy <sup>®</sup> C-276	PTFE or FKM O-ring	Integral	Tee

### STANDARD MATERIALS - SOFT SEAT

Valve	Body	Bonnet	Stem	Packing	Flow washer	Seat	Handle <sup>[2]</sup>
CS <sup>[1]</sup>	A108	A108	A581-303	PTFE or FKM O-ring	A479-316	Delrin <sup>®[4]</sup>	Round
SS	A479-316	A479-316	A276-316	PTFE or FKM O-ring	A479-316	PCTFE <sup>[5]</sup>	Tee
Brass	B16	B16	A581-303	PTFE or FKM O-ring	A479-316	Delrin <sup>®[4]</sup>	Round
SG <sup>[3]</sup>	A479-316	A479-316	Monel <sup>®</sup> R405	PTFE or FKM O-ring	A479-316	PCTFE <sup>[5]</sup>	Tee
SG3 <sup>[6]</sup>	Hastelloy <sup>®</sup> C-276	Hastelloy <sup>®</sup> C-276	Hastelloy <sup>®</sup> C-276	PTFE or FKM O-ring	Hastelloy <sup>®</sup> C-276	PCTFE <sup>[5]</sup>	Tee

#### NOTE

1. CS is zinc chromate plated to prevent corrosion.
2. Tee handle is SS; round handle is CS.
3. SG (Sour Gas) meets the requirements of NACE MR0175/ISO 15156 (for chloride conditions < 50 mg/l [ppm]) and NACE MR0103.
4. PEEK available.
5. PCTFE (Polychlorotrifluoroethylene) is the exact equivalent of Kel-F<sup>®</sup>.
6. SG3 (Sour Gas) meets the requirements of NACE MR0175/ISO 15156 (for chloride conditions > 50 mg/l [ppm]).

### BONNET ASSEMBLY OPTIONS

The H5 features the mini-valve bonnet assembly, with a compact design and a one-piece rotating stem which is 'V' tipped with a shoulder for use as a metal or soft seated valve. The stem threads are rolled and lubricated to prevent galling and reduce operating torque.

#### The mini-valve bonnet comes in three designs:

- An adjustable PTFE stem packed bonnet which is suitable for panel mounting via external bonnet threads.
- O-ring bonnet assemblies which use a FKM O-ring seal below the stem thread.
- A graphite-packed bonnet suitable for temperatures of up to 1000°F (538°C) which is available for SS valves only.

# ANDERSON GREENWOOD H5 MINIATURE HAND VALVE

## SPECIFICATIONS

PRESSURE VS. TEMPERATURE - CS and SS valves

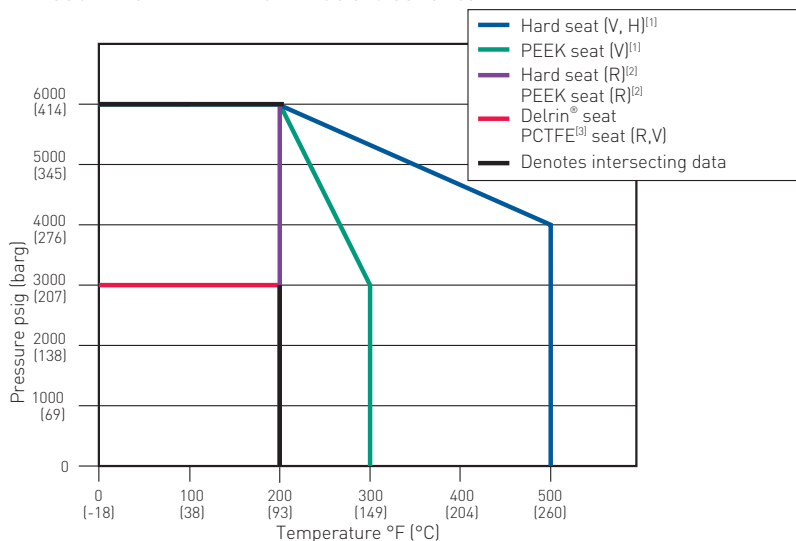

PRESSURE VS. TEMPERATURE - Brass valves

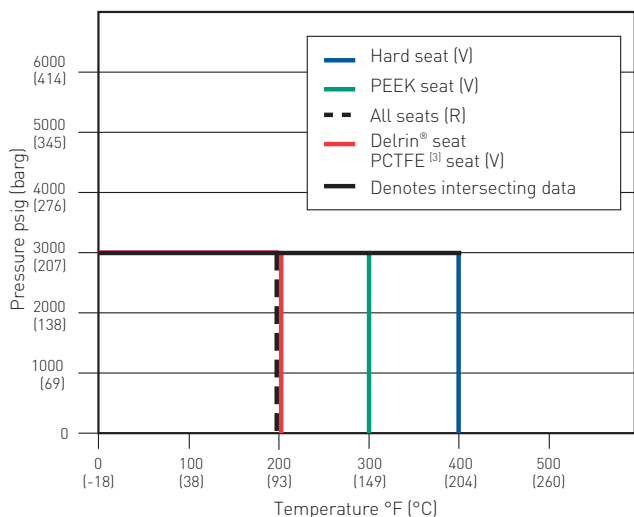

PRESSURE VS TEMPERATURE - SS valves with Grafoil<sup>®</sup> bonnet

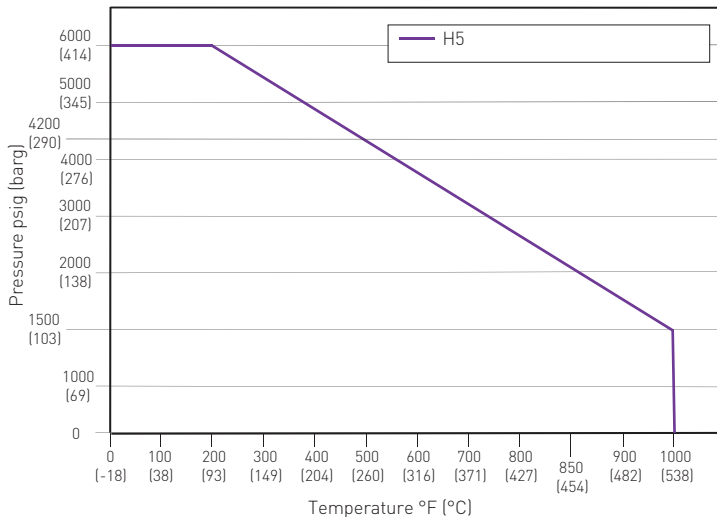

### NOTES

- (V or H) = with PTFE or GRAFOIL<sup>®</sup> bonnet assemblies.
- (R) = with O-ring bonnet assembly.
- PCTFE (Polychlorotrifluoroethylene) is the exact equivalent of Kel-F<sup>®</sup>.

### PRESSURE AND TEMPERATURE RATINGS<sup>[1]</sup>

Seat	PTFE bonnet		GRAFOIL <sup>®</sup> bonnet <sup>[2]</sup>
	CS and SS valves	Brass valves	SS valves
Hard	6000 psig at 200°F (414 barg at 93°C) 4000 psig at 500°F (276 barg at 260°C)	3000 psig at 400°F (207 barg at 204°C)	6000 psig at 200°F (414 barg at 93°C) 1500 psig at 1000°F (103 barg at 538°C)
Delrin <sup>®</sup> and PCTFE <sup>[3]</sup>	3000 psig at 200°F (207 barg at 93°C)	3000 psig at 200°F (207 barg at 93°C)	
PEEK	6000 psig at 200°F (414 barg at 93°C) 3000 psig at 300°F (207 barg at 149°C)	3000 psig at 300°F (207 barg at 149°C)	
	O-ring bonnet		
Hard	6000 psig at 200°F (414 barg at 93°C)	3000 psig at 200°F (207 barg at 93°C)	
Delrin <sup>®</sup> and PCTFE <sup>[3]</sup>	3000 psig at 200°F (207 barg at 93°C)	3000 psig at 200°F (207 barg at 93°C)	
PEEK	6000 psig at 200°F (414 barg at 93°C)	3000 psig at 200°F (207 barg at 93°C)	

### NOTES

- Pressure and temperature ratings are not shown on valve body.
- GRAFOIL<sup>®</sup> packed bonnet comes complete with ball end stem; SS only. 1000°F (538°C)

# ANDERSON GREENWOOD H5 MINIATURE HAND VALVE

## SPECIFICATIONS

OPTIONAL PANEL MOUNTING NUT<sup>[1]</sup>  
inches (mm)

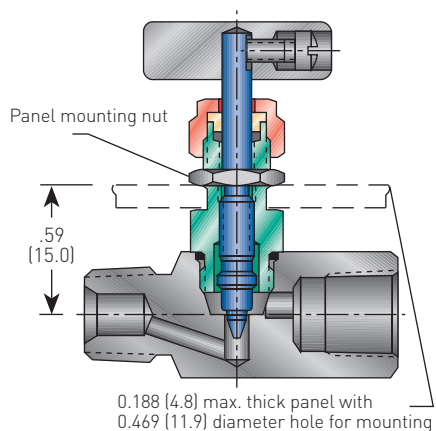

OPTIONAL SOFT SEAT<sup>[2]</sup>

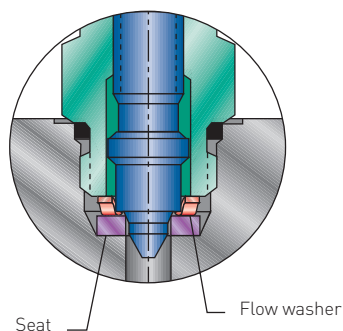

OPTIONAL PHENOLIC HANDLES<sup>[2]</sup>

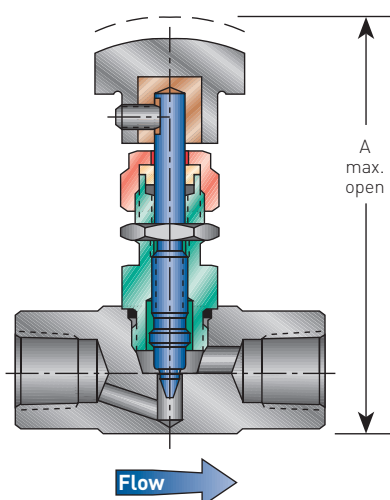

OPTIONAL GRAFOIL<sup>®</sup> PACKED BONNET

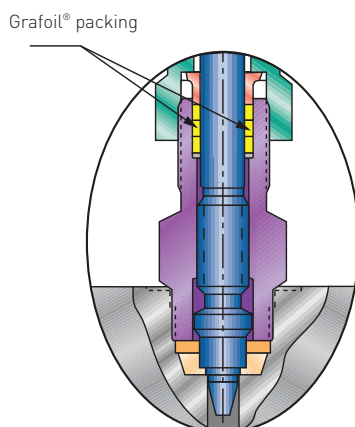

Phenolic handles are available in 1 inch (25 mm) diameter. Colors available are green, red, and black. Phenolic handles facilitate repeatable flow control, as well as enhancing the appearance of panels, sample cylinders and other associated products requiring premium performance throttling and/or isolation valves.

Maximum open dimension of any H5 with Phenolic handles is calculated by adding 0.4 inch (10.2 mm) to the 'A' reference dimension for PTFE stem seal on page 2.

### NOTE

1. Available with PTFE packed bonnet.
2. Available on all H5 products.

# ANDERSON GREENWOOD H5 MINIATURE HAND VALVE

## SPECIFICATIONS

### SELECTION GUIDE

Example:	H5	V	D	S	-22	-SG
<b>Packing</b>						
<b>V</b>	PTFE (standard for SS)					
<b>R</b>	O-ring					
<b>H</b>	GRAFOIL® (SS only) 1000°F (538°C) max.					
<b>Seat</b>						
<b>I</b>	Integral					
<b>D</b>	Delrin®					
<b>E</b>	PEEK					
<b>K</b>	PCTFE <sup>11</sup> (standard for SS)					
<b>Material</b>						
<b>B</b>	Brass					
<b>C</b>	Carbon steel					
<b>S</b>	316 SS					
<b>J</b>	Hastelloy®					
<b>Connections</b>						
<b>2</b>	¼ inch FNPT (outlet) x ¼ inch FNPT (inlet)					
<b>2A</b>	¼ inch FNPT (outlet) x ¼ inch FNPT (inlet) angle					
<b>2M</b>	¼ inch MNPT (outlet) x ¼ inch MNPT (inlet)					
<b>22</b>	¼ inch FNPT (outlet) x ¼ inch MNPT (inlet)					
<b>22A</b>	¼ inch FNPT (outlet) x ¼ inch MNPT (inlet) angle					
<b>Options</b>						
<b>CL00</b>	Chlorine cleaning					
<b>HD</b>	Hydrostatic testing (100%) (MSS-SP-61)					
<b>MS</b>	Monel® stem					
<b>OC00</b>	Oxygen cleaning (316 SS only)					
<b>PHB</b>	Phenolic black handle					
<b>PHG</b>	Phenolic green handle					
<b>PHR</b>	Phenolic red handle					
<b>PM</b>	Panel mount (PTFE packed only)					
<b>SG</b>	Sour Gas meets the requirements of NACE MR0175/ISO 15156 (for chloride conditions < 50 mg/l (ppm)) and NACE MR0103-2005 (SS only)					
<b>SG3</b>	Sour Gas meets the requirements of NACE MR0175/ISO 15156 (for chloride conditions > 50 mg/l (ppm))					

### NOTE

1. PCTFE (Polychlorotrifluoroethylene) is the exact equivalent of Kel-F®.

Delrin® is a registered trademark of E.I. du Pont de Nemours and Company.

Grafoil® is a registered trademark of GrafTech International.

Hastelloy® is a registered trademark of Haynes International, Inc.

Kel-F® is a registered trademark of 3M Company.

Monel® is a registered trademark of the Special Metals Corporation.