

The Model 5126 "Freezeless" dump valve is perfectly suited for fluid control in oil and gas separators and other process vessels. The valves body design causes the plug and seat to be constantly submerged in the process media, thus giving the valve its "Freezeless" characteristic.

Features:

- **Simple Maintenance** - Valve trim or the complete actuator assembly can be quickly changed by simply removing the hammer nut and lifting the actuator assembly off the valve body. Disassembly of the actuator or removal of the valve from the line is not required. No special tools are required.
- **Simple Installation** - Compact, light-weight design enables quick, easy installation with minimal labor requirements.
- **Hardened Trim** - Dump valve trim is available in 17-4PH stainless steel or Tungsten Carbide to handle the most difficult applications.
- **Bonnet Safety Pressure Relief** - Special design of hammer nut provides warning indication if an attempt is made to remove the actuator while the valve body is still under pressure (see Figure 1).
- **Marine Option** - Makes this dump valve ideally suited for harsh marine environments where corrosion and salt build-up are a problem. A combination of stainless steel parts and special actuator preparation makes the "Marine Option" a valuable feature.



Specifications:

Body Style

Angle

Connections / Pressure Rating

2" mnpt x 1" fnpt / 1500 psig (103 bar)

Trim Size / Flow Characteristic / Flow Coefficients

1/4" quick opening:	1.4 C _V
1/4" modified percent	1.3 C _V
3/8" quick opening	2.0 C _V
3/8" modified percent	1.9 C _V
1/2" quick opening	2.3 C _V
1/2" modified percent	2.2 C _V

Maximum Differential Pressure

1500 psig

Assembled Valve Temperature Limits

With Buna seals: -20 to 180°F (-29 to 82°C)

With Viton seals: -20 to 200°F (-29 to 93°C)

Materials of Construction

Valve Body:	1018 Steel
Bonnet:	1018 Steel, electroless-nickel coated
Hammer Nut:	Carbon Steel
Trim:	17-4Ph SST Tungsten Carbide (optional)
Valve Stem:	303 SST 316 SST (optional)
Packing:	PTFE V-Ring
Seals:	Buna Viton (optional)
Diaphragm Hsgs:	Steel
Diaphragm:	Buna reinforced with Nylon Fabric
Actuator Spring:	Steel

Approximate Valve Weight

With No. 35 Actuator: 25 Lb. (11.3 Kg)

With No. 70 Actuator: 35 Lb. (15.8 Kg)

ANSI Leakage Rating

Class IV

Bonnet Safety Pressure Relief

The left picture in Figure 1 shows the hammer nut in the "locked" position during normal operation.

The right picture in Figure 1 illustrates the "Bonnet Safety Pressure Relief". The O-Ring clears the packing plug while the hammer nut is still engaged (threaded) onto the valve body. At this point, if the valve assembly is under pressure, process fluid will escape through the weep hole to indicate a warning to the service person that the valve is still under pressure, thereby prompting him to remove line pressure before proceeding, thus preventing the actuator assembly from "blowing" out.

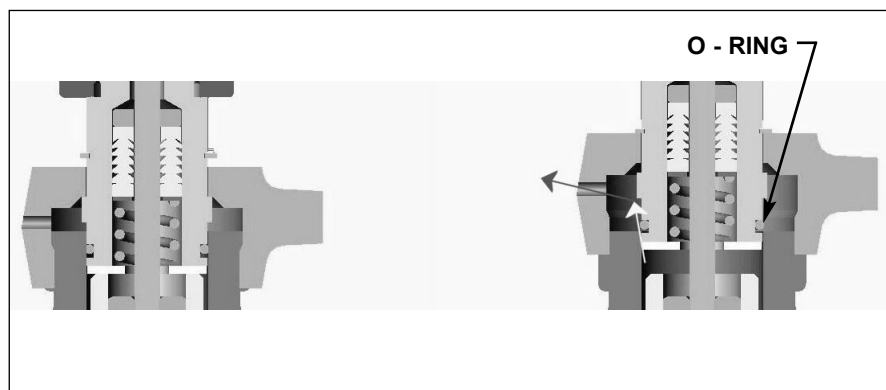
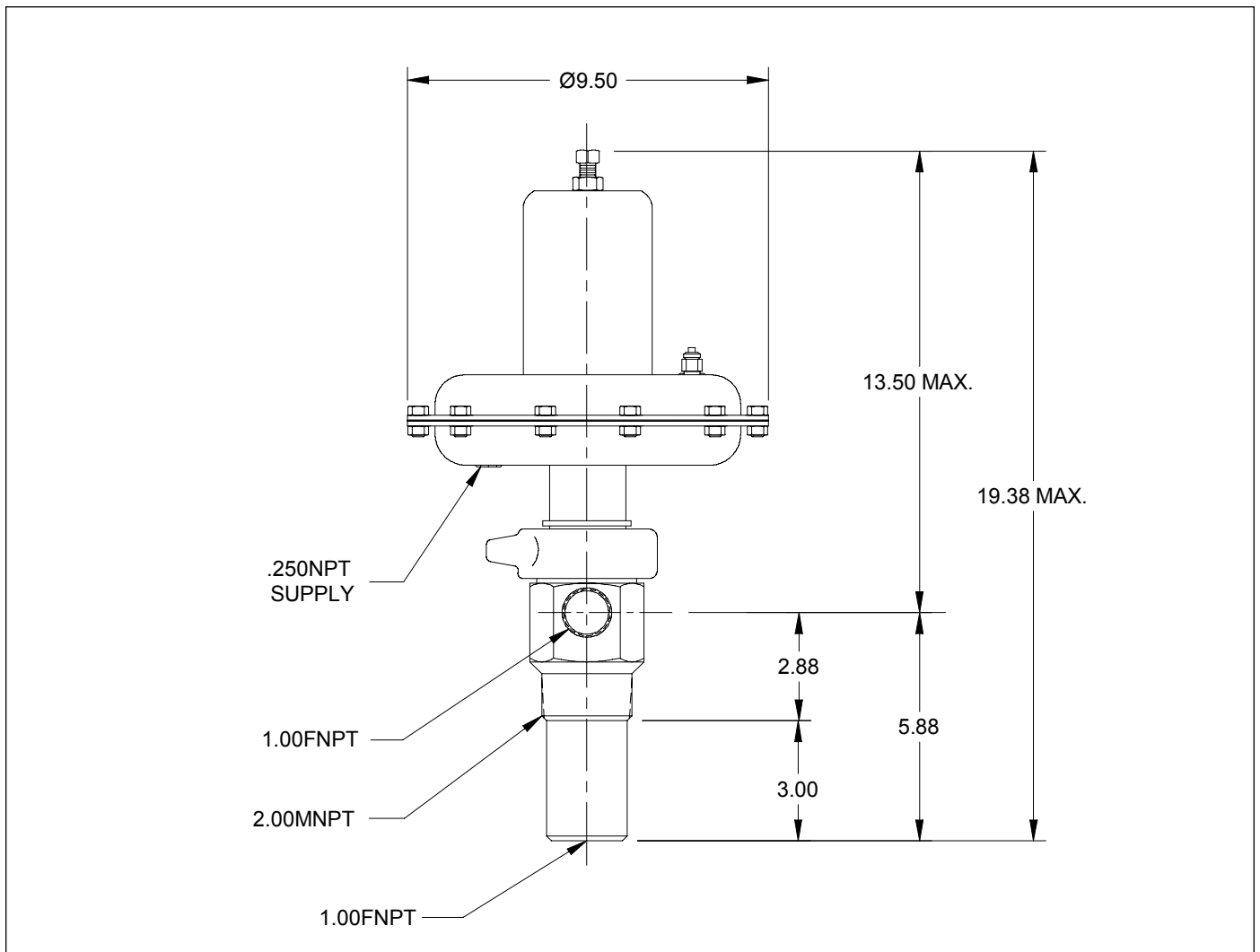

Figure 1. Bonnet Safety Pressure Relief

Dimensions



Model Number Information

Sample Model Number: **5126 - 2 R 35 B - 1 2 Q**

PROCESS CONNECTION	CODE							
2" mnpt x 1" fnpt	2							
ACTUATOR TYPE	CODE							
Direct Acting (Fail Open) Non-adjustable	B							
Reverse Acting (Fail Close) Non-adjustable	C							
Direct Acting (Fail Open) Adjustable	D							
Reverse Acting (Fail Close) Adjustable	R							
ACTUATOR SIZE	CODE							
No. 35	35							
No. 70	70							
SEAL MATERIAL	CODE							
Buna	B							
Viton	V							
MATERIALS OF CONSTRUCTION	CODE							
Carbon Steel - Standard Service	-							
Carbon Steel - Marine Option	M							
Carbon Steel - NACE Option	N							
Carbon Steel - Marine, NACE Options	R							
TRIM MATERIAL	CODE							
17-4PH SST	1							
Tungsten Carbide	2							
TRIM SIZE	CODE							
1/4"	2							
3/8"	3							
1/2"	4							
TRIM CHARACTERISTIC	CODE							
Quick Opening (on/off)	Q							
Modified Percent (throttling)	M							

While this information is presented in good faith and believed to be accurate, Mallard Control Company does not guarantee results based upon such information. Mallard Control Company reserves the right to change the design or specifications of these products without notice.

Mallard Control Company, Inc.

4970 Washington Boulevard
 Beaumont, Texas, USA 77707
 409 842-5392 Phone
 409 842-8165 FAX
 www.MallardControl.com